

Power Bridge Rectifiers

SKD 51

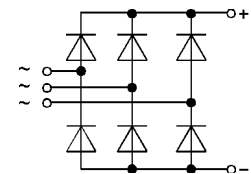

Features

- Glass passivated silicon chips
- Fast-on terminals for pcb solder or plug-on connection
- Sturdy isolated metal base plate
- Low thermal impedance through use of direct copper bonded aluminum substrate (DCB)
- Blocking voltage up to 1800 V
- High surge currents
- UL recognized, file no. E63 532

Typical Applications

- Three phase rectifiers for power supplies
- Input rectifiers for variable frequency drives
- Rectifiers for DC motor field supplies
- Battery charger rectifiers

V_{RRM}	V_{RSM}	V_{VRMS}	I_D ($T_{case} = 127\text{ °C}$) 50 ¹⁾ A
400	500	125	SKD 51/04
800	900	250	SKD 51/08
1200	1300	380	SKD 51/12
1400	1500	440	SKD 5114
1600	1700	500	SKD 51/16
1800	1900	570	SKD 51/18*

Symbol	Conditions	SKD 51	Units	
I_D, I_{DCL}	$T_{case} = 127\text{ °C}$	50 ¹⁾	A	
	$T_{amb} = 45\text{ °C}$; isolated ²⁾	7	A	
	chassis ³⁾	18	A	
	R4A/120	27	A	
	P5A/100	31	A	
	P1A/120	52	A	
I_{FSM}	$T_{vj} = 25\text{ °C}$; 10 ms	775	A	
	$T_{vj} = 150\text{ °C}$; 10 ms	700	A	
i^2t	$T_{vj} = 25\text{ °C}$; 8,3 ... 10 ms	3000	A ² s	
	$T_{vj} = 150\text{ °C}$; 8,3 ... 10 ms	2450	A ² s	
V_F	$T_{vj} = 25\text{ °C}$; $I_F = 75\text{ A}$	1,45	V	
$V_{(TO)}$	$T_{vj} = 150\text{ °C}$	0,8	V	
r_T	$T_{vj} = 150\text{ °C}$	8,5	mΩ	
I_{RD}	$T_{vj} = 25\text{ °C}$; $V_{RD} = V_{RRM}$	0,2	mA	
	$T_{vj} = 150\text{ °C}$; $V_{RD} = V_{RRM}$	4	mA	
t_{rr}	$T_{vj} = 25\text{ °C}$; $I_F = I_R = 1\text{ A}$	typ. 5	μs	
f_G		2000	Hz	
R_{thjc}	per diode	1,1	°C/W	
	total	0,183	°C/W	
	R_{thch}	total	0,1	°C/W
		isolated ²⁾	9	°C/W
	R_{thja}	chassis ³⁾	3,15	°C/W
		P5A/100	1,8	°C/W
		R4A/120	1,15	°C/W
P1A/120	0,883	°C/W		
T_{vj}		- 40 ... + 150	°C	
T_{stg}		- 40 ... + 125	°C	
V_{isol}	a. c. 50 Hz; r.m.s; 1 s/1 min	3600 / 3000	V~	
	$P_R = 1\text{ W}$	50	Ω	
RC		0,1	μF	
	Case to heatsink	4,5 ± 15 %	Nm	
M_1	SI units	40 ± 15 %	lb. in.	
	US units	97	g	
Case	→ page B 11 – 38	G 51		

* available in limited quantities

1) For solder connection.

Permissible current for plug connection see DIN IEC 760E and DIN 46249 part 1

2) Freely suspended or mounted on an insulator

3) Mounted on a painted metal sheet of min. 250 x 250 x 1 mm

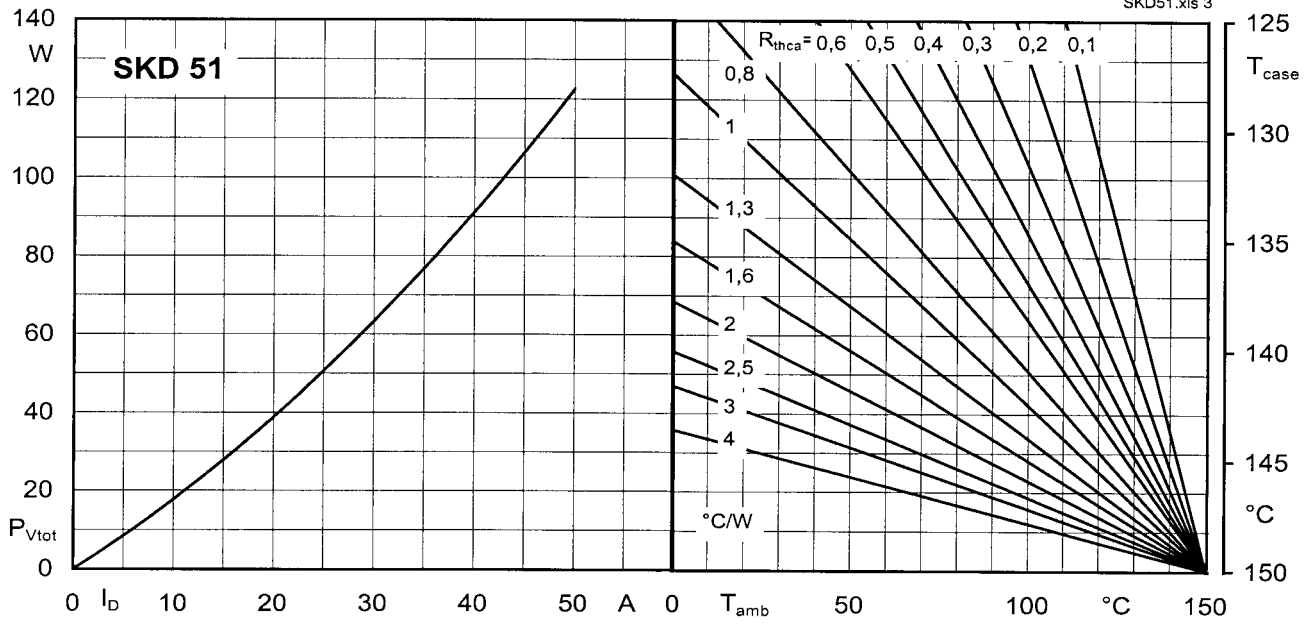
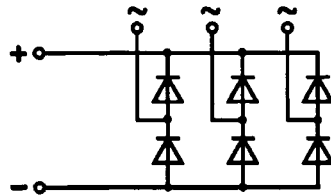
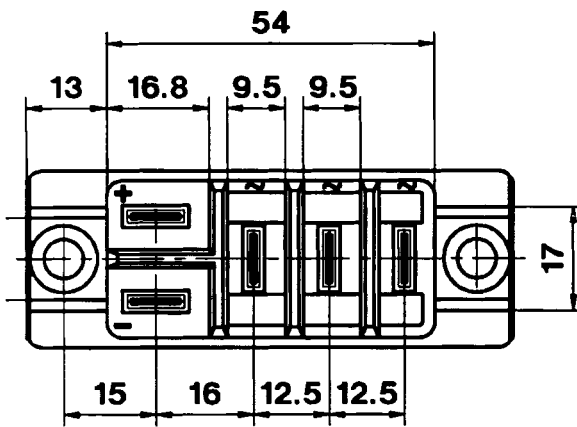
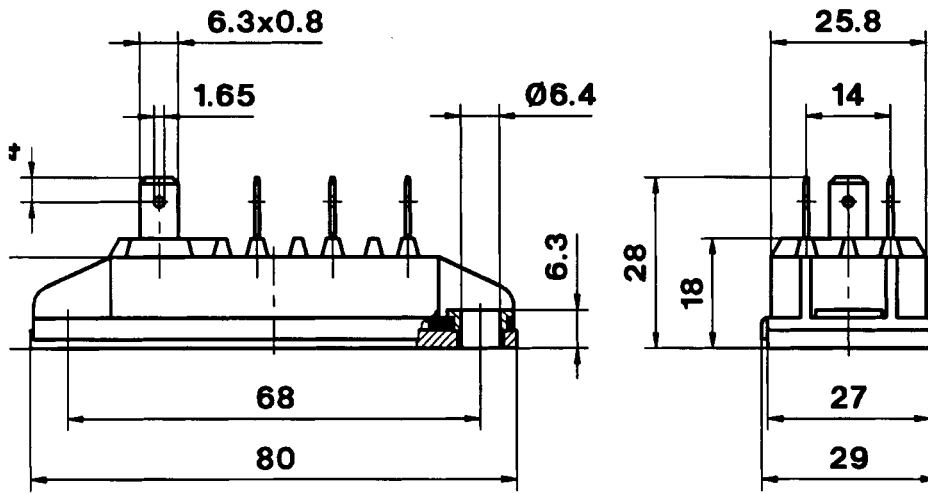

Fig. 3 Power dissipation vs. output current and case temperature

SKD 51
Case G 51



Dimensions in mm